



Lube Oil Blending – An Overview for Lube Plants

by J. J. Jiskoot, Jiskoot Ltd
Blending Seminar, Singapore

The blending of liquids and solids is an art which goes back to the early Stone Age and in its simplest form could look something like this.



From this we can move to a more accurate method using a P.D. meter with 'set-stop' as shown here.

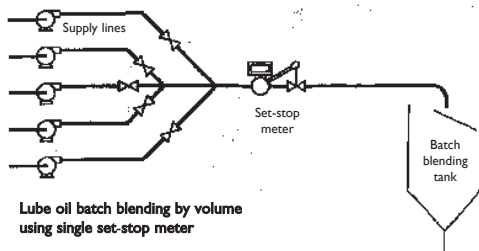

Go a stage further and we can produce batches using a weighing method such as shown below in which each ingredient is discharged sequentially and weighed into the mixing tank (kettle).

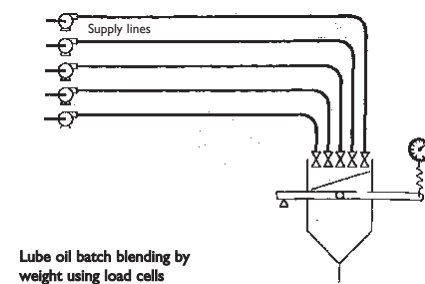

Another method is to use dedicated meters to measure each component into a recycle-loop. This method is often called 'stream blending' and in the diagram below is shown with an additional in-line dehydrator mounted in the loop.

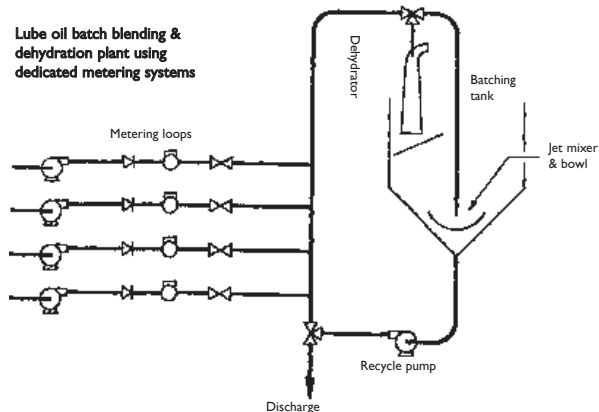

Another more sophisticated approach is batch blending which is shown on the right. Batch blending lube-oil in this manner is often called 'cascade blending'.

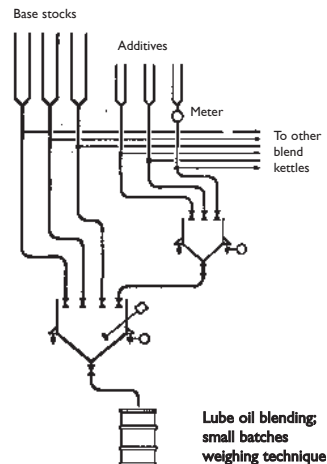

Blending Techniques for Lube Oil Plants

If the blending plant building height allows, cascade blending can produce very accurate batches, very quickly with a minimal risk of contamination. Base components can be metered/weighed into a 'kettle' before pre-mixing (cocktailing) which can be flushed clean to avoid contamination.

Contamination is the main concern of the lube-oil blender. Base products and additives are expensive and mis-blending or contamination of the final product may mean down-grading the product or using it to feed the burners. To avoid contamination it is imperative that products are produced in 'closely-related family groups', or entirely separately using different mixing tanks. Subsequent flushing and efficient pigging are also essential tools to combat contamination.

In any of the previously mentioned blending methods you take the ingredients to the mixing pot. When this gets scaled-up, in a lube blending plant, it means that almost every one of the base stocks and additives have to be available and measured at the mixing/blending point. This involves a lot of piping, pumps, valves and hose exchanges etc.

An alternative approach is to take 'the mixing pot to the ingredients'. Such a system can drastically reduce the supply piping since the actual mixing vessels are transported, in turn, to one or two points in the plant where all the base stocks and additives are available through dedicated supply lines. Small volume additive metering would normally be done by volume and large components either metered or weighted (by placing the batch-tank on load cells). The batch tank is then transported to a mixing station and eventually discharged after laboratory checks, using a specialised system of conveyors and/or robots.

Lube oil batch/weigh system

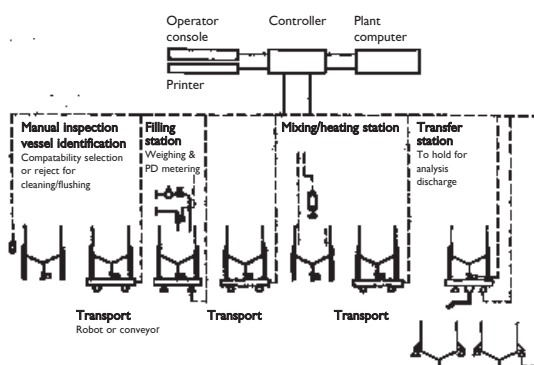

This type of system (shown above) requires a purpose built plant and tends to limit the batch size to about 5 tons, due to transport considerations. If used in conjunction with load cells (with an accuracy/linearity of 0.04% over 10 to 1 range) the small volume additives may have to pre-mixed by cocktailing or dilution before the final process.

As you can see, batch blending is not an instantaneous process. The sequential metering followed by mixing and analysis can take several

hours, depending on batch size and the system employed. The picture below shows one of our lube batch blending plants in which some of these mixing problems have been reduced by building the blender around a Jiskoot Lube-Oil Dehydrator. The dehydrators' recycling feature allows the components and additives to be almost simultaneously metered into the unit which then dehydrates and mixes them prior to discharge.

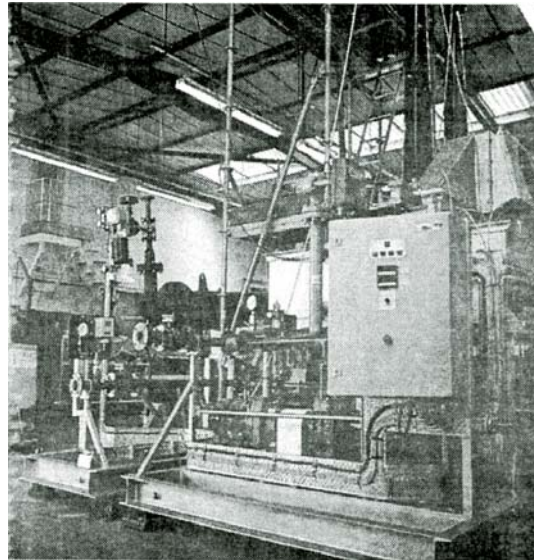

To summarise batch blending, in its various shapes and guises, I believe that no lube-oil blending plant can do without it, but I also believe that the constraints mentioned early indicate the limitations.

An average/large lube-oil blending plant will use 300 - 400 formulations/finished grades to produce maybe 10,000 batches per annum. The majority of these will be small with individual batch volumes rarely exceeding 2 - 3 tons thus creating serious contamination hazards. The special/high quality blend sector can account for 35 - 40% of annual tonnage. In today's high cost atmosphere special care and attention in production planning is essential. This is the reason existing lube blending plants have put greater emphasis on pigging lines, extra flushing and installing dedicated metering lines etc.

A schematic of a typical modern lube blending plant is shown at the top of the next page.

Production starts on the left with the incoming base components and additives in storage tanks. The additives usually require some pre-treatment such as heating, decanting or maybe solids/waxes added. These are often cocktailed before being stored ready for the blending process.

The base components may be wet and require dehydration, which can be done with an in-line lube-oil dehydrator, or heat and an air-sparger blowing in the stock tank (the latter can take some hours).

The batch and in-line blenders take these components and additives and turn them into the final blended products that are discharged to storage,

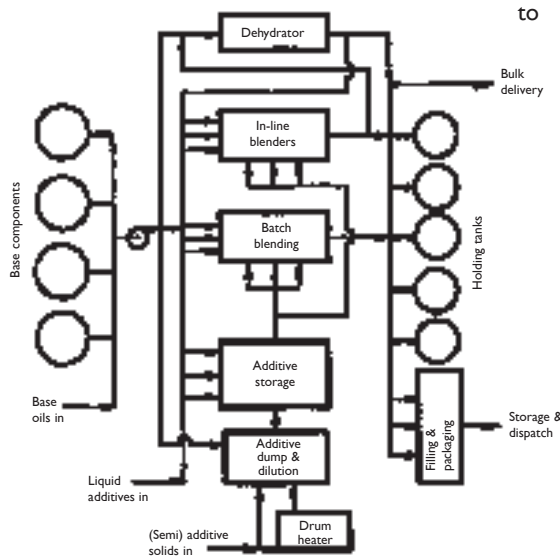

filling machines or despatched in bulk. The laboratory checks this entire process from start to finish to ensure quality.

In-line blending is a technique that any lube blending plant producing more than 20,000 TPA. could use to great advantage.

In its very basic schematic form an in-line blender looks like this.

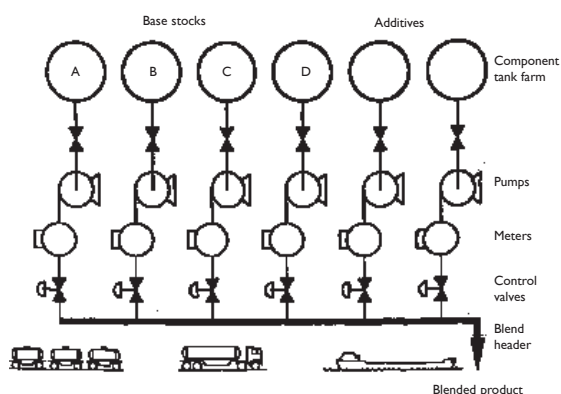

Each component/base stock stream is accurately controlled and the blend header discharges a final blended product that is correct from start to finish.

The advantages of such a system are:

1. Lower production times and labour costs through an almost immediate response to market demand (i.e. 'you press a few buttons' and the final product is immediately available). No long mixing delays and hold-ups in large tanks.
2. Better quality control, therefore reduced give-away because even the smallest additive is metered accurately and dispersed evenly from start to finish.
3. Reduced final blended product storage requirements therefore saving on tankage, stock inventory, etc. - reduced capital lock-up.

to 4. Reduced labour requirements - reduced floor area.

Whilst in-line blending does offer many advantages, there will always be a place in a lube-oil plant for batch blending facilities; if only because it is such a simple method with excellent operational flexibility when it comes to smaller batch sizes. It provides an almost infinite number of permutations of batch sizes and options of metering/weighing and degree of automation etc.

Let us now look at some of the limitations of in-line blending:

- There is an economical minimum size for an in-line lube blender of approximately 60 - 80 GPM blend rate (16 -21 m³ /Hr). This is primarily caused by the minimum acceptable size of commercially available flow meters for metering additives at percentages as low as 0.1 - 0.2% of blend rate and the general volume/area ratios of piping, strainer, meters etc. An in-line blender, as opposed to a batch blender, relies heavily on meter rangeability and this tends to tail off with meters below 1/2". The employment of metering pumps is often used for these low flow applications.
- One normally only has 7 or 8 streams in an in-line blender. This means that some planning is necessary to avoid the same metering stream being used for non-compatible components in successive batches. However the lay-out of a well designed lube blender means that one can adequately clear out piping and strainers, etc.

As a consequence of these limitations, we have adopted the following basic rules when consulted on batch and in-line lube blenders for the 'average' plant.

1. An in-line blender can be economically justified for an annual production figure of 18,000 tonnes and over
2. About 60% (plus) of total tonnage can normally be considered as large batch (fast movers) and ideal for an in-line blender
3. If there is a slight contamination hazard between successive batches the batch size should not be smaller than the equivalent of 4-5 minutes of the maximum blend rate (i.e. for a 100 GPM blender this would be 500 Gallons). This can be reduced for 'family related' blends. By inference production planning should be governed by the compatibilities of successive blends.
4. Daily utilisation of a typical in-line blender averages at approximately 5 hours with a quality confidence of 99.9%.



The photo (right) show 3 blending systems installed, to segregate feedlines, hydraulics, automation and industrial products.

The photo below shows a typical hose exchange, where the physical selection of base stocks and additives with which this in-line blender is supplied takes place.

The last figure is a schematic illustration of a lube plant I worked on a little while ago. The system was designed to utilise as much of the existing plant as possible.

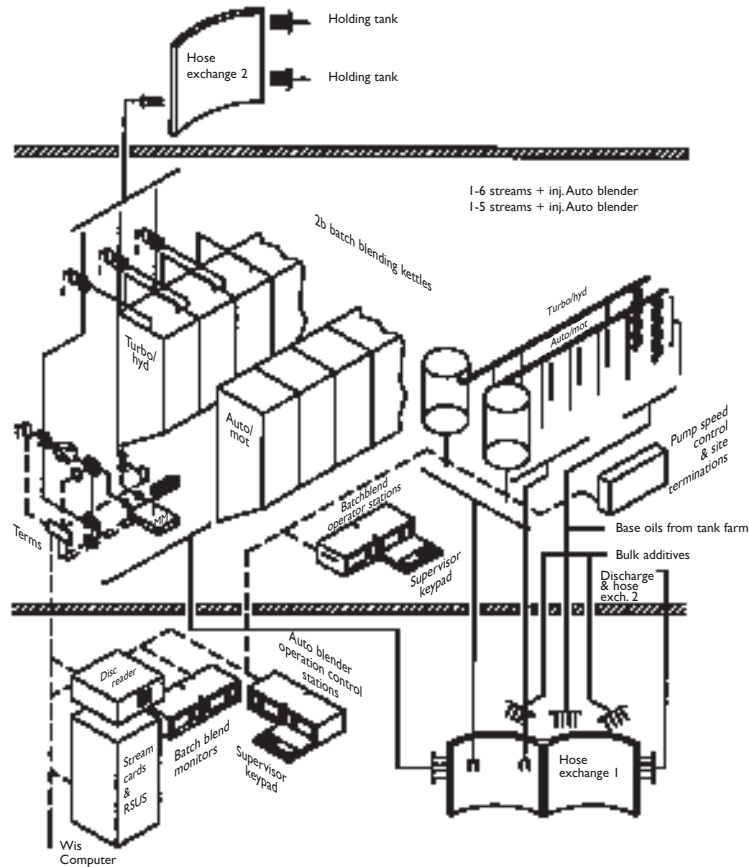
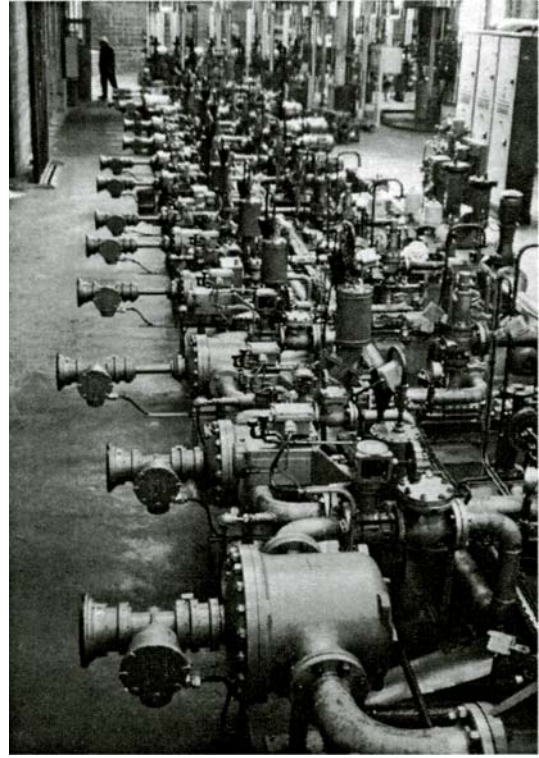
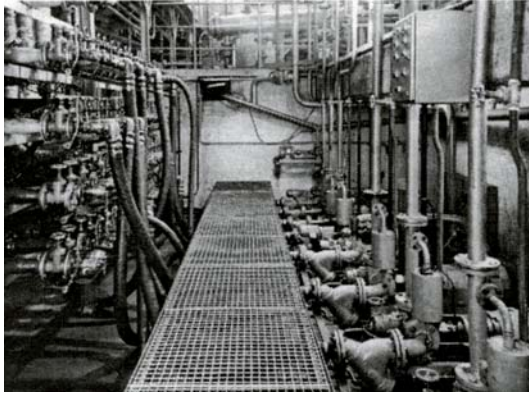

MEASUREMENT SYSTEMS

DIVISION HEADQUARTERS
HOUSTON, TEXAS
+1 800 654 3760

JISKOOT QUALITY SYSTEMS
HEADQUARTERS
TUNBRIDGE WELLS, KENT, UK

+44 1892 518000
ms-jiskootinformation@c-a-m.com

JISKOOT QUALITY SYSTEMS
US TECH CENTER
HOUSTON, TEXAS

+1 281 582 9500
ms-jiskootsales@c-a-m.com

USA • CANADA • UK • CHINA • UAE • ALGERIA • MALAYSIA • INDIA • KENYA

www.c-a-m.com/jiskoot



MEASUREMENT SYSTEMS