



# Bunker Blending

Blending bunker fuel at the lowest cost to meet a customer's specification is the goal of any bunker supplier. Rising costs and fluctuations in feedstock quality make this more difficult and the increasing number of disputes put any supplier without a record of quality and quantity at risk. As a result, many suppliers produce higher specification products than needed.

A two-year test of 380Cst fuel showed that suppliers were, on average, supplying 280Cst and therefore using much more distillate than necessary to manufacture the fuel supplied.

A Jiskoot in-line blender could significantly reduce this production cost by minimising the distillate 'give away'.



In the competitive and volatile bunker market, a Jiskoot in-line blender can pay for itself in less than 6 months. At the push of a button it produces a range of fuel oils that meet specification at the lowest possible cost with all the required documentation.

Jiskoot in-line blenders are designed specifically for each application and use a real-time closed loop control system. This gives much higher accuracy than mechanical or batch blenders.

Jiskoot blenders use a controller with unique control algorithms that respond instantly to changes in process conditions or feedstock quality. The heavy fuel oil and cutter stock are continuously measured and adjusted during the batch to ensure optimum quality and minimum 'give-away'. Jiskoot systems are designed to ensure consistent quality throughout the batch even during tank changes, feedstock starvation, loss of power or the unlikely failure of a system component.



*Viscosity trim in-line blender*

The final product is mixed in the blender header to ensure consistency and the accuracy of any viscosity measurement fitted. This also provides an ideal location for an automatic sampler.

Jiskoot blenders are simple to use. The desired recipe and volume or mass is selected from the controller and the blend started. Once initiated; the blending process is automatic and produces the final product with no intervention, only informing an operator if an alarm condition occurs.

The control system produces all billing, loading and transaction documents including trend reports for major parameters (such as viscosity) in case of dispute.

Blenders can be skid mounted (for installation on a barge, jetty or shore), mounted in a container offering a portable, safe working environment or self-contained on a trailer allowing one blender to be used at multiple locations.

Jiskoot offers a range of services to suit your budget, from review of existing equipment and system design through to the supply of an upgrade control or complete blending systems. We have strategic alliances with major manufacturers worldwide giving you a guarantee of first class customer support.



*Blender for barge installation*

With over 40 years' experience of the design and supply of fuel oil blending solutions, we understand what is important to your business.

### Reduce production costs

Jiskoot blenders use a closed loop controller to measure and control each stream being blended. This guarantees the lowest cost production across a wide operating range reducing your distillate 'give-away'.

### Automatic quality control

The controller continually monitors the blending process in real time and responds instantly to changes in quality or quantity. When viscosity trim is installed, the blended fuel oil is produced to a target viscosity at standard conditions with full documentation.

### Product always on specification

The 'CutBack' feature of a Jiskoot blender keeps the blended product on specification throughout the blend even in the event of product starvation, large feed rate changes or power failure.

### Volume and viscosity correction to standard conditions

The blender performs volume and viscosity correction to API, IP and ASTM. This data can be displayed or used in reports, including bills of lading. The controller uses flow-weighted averages to eliminate the errors associated with time-based systems.

### Quality and quantity documentation

The controller produces a range

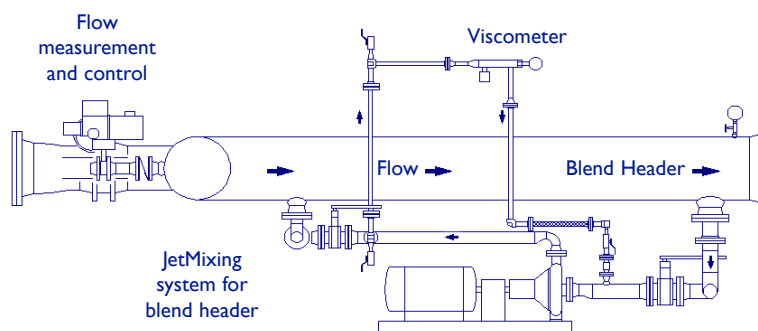

of documentation for the blended batch including a bill of lading. Controller displays and documentation can be in either volume or mass units (bbls/m3 or tonnes).

### Multiple recipe management

The controller can store up to 200 pre-configured recipes and 'instant' recipes can be entered at the start of any new blend.

### Single product loading

One or both streams of the blender can be used for bulk loading a single product with measurement and documentation.

### Simple user interface with security

The operator interface is easy to use and features multi-level security to lock key configuration and recipe functions.

### Large throughput and turn-down

Jiskoot in-line blenders have a high turndown. This allows you to use the blender for a wide range of parcel sizes and customers, maximising the flexibility of your operation.

*Fuel oil bunker blender*



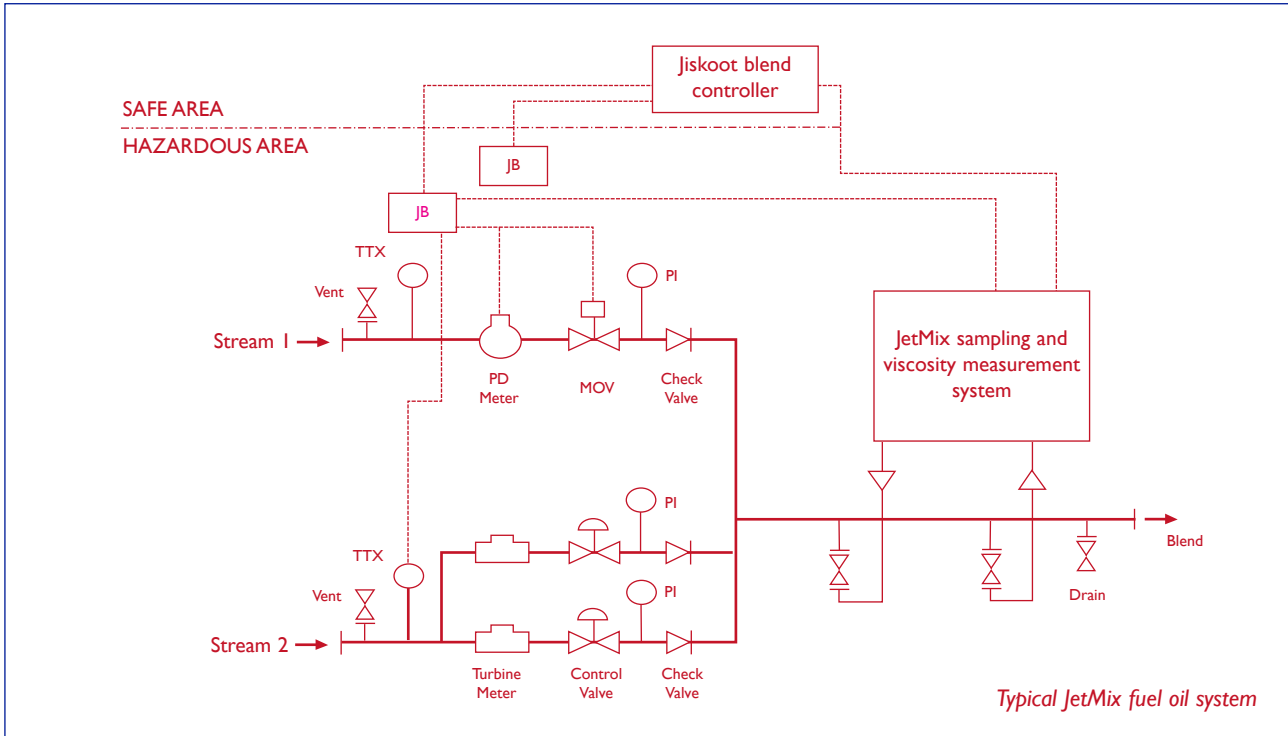

### Blender options

- Ratio control blender  
*(high accuracy ratio control)*
- Viscosity control blender  
*(high accuracy with viscosity measurement and automatic adjustment of ratio to target viscosity)*
- Hazardous area controller
- Safe area controller
- Intrinsically safe control panel  
*(at point of loading)*
- PC based SCADA system  
*(System Control And Data Acquisition)*
- Flow proportional sampler
- Drip sampler

### Implementation options

- Manufacture a new blender using your existing metering and control equipment.
- Retrofit viscosity measurement and control system to your existing blender
- Design and manufacture a new blender specifically for your application

### Installation options

- Barge mounted
- Containerised
- Trailer mounted
- Fixed installation

*Jiskoot offers a complete range of services for fuel oil blending and sampling. Please contact us, or our local representative to discuss your needs.*



**UK**  
Jiskoot Quality Systems  
Tel: +44 (0)1892 518000  
Fax: +44 (0)1892 518100

Email: [ms-jiskootuksales@c-a-m.com](mailto:ms-jiskootuksales@c-a-m.com)

**USA**  
Jiskoot Quality Systems  
Tel: +1 281 583 0583  
Fax: +1 281 583 0587

Email: [ms-jiskootusasales@c-a-m.com](mailto:ms-jiskootusasales@c-a-m.com)

**Cameron**  
Measurement Systems  
Tel: +1 281 582 9500  
Fax: +1 281 582 9599

Email: [ms-marketing@c-a-m.com](mailto:ms-marketing@c-a-m.com)

Jiskoot Quality Systems  
A Cameron Company  
[www.jiskoot.com](http://www.jiskoot.com)  
  
[www.c-a-m.com/flo](http://www.c-a-m.com/flo)