



# 210EH Probe & 210EH-HP Probe

## Hydraulically actuated in-line sample extractor



The 210EH Probe is a reliable and accurate sample extraction device, suitable for use as part of an in-line sampling system. Available in standard and high-pressure versions the 210EH is hydraulically operated and includes a self contained hydraulic pack making it an ideal solution for a wide range of liquid sampling applications where an air supply is unavailable.

The 210EH Probe has a unique three-stage positive displacement action giving accurate sampling irrespective of variations in process pressure or fluid viscosity.

The mechanism that traps the sample is at the end of the insertion device and has a pitot style, large flow entry minimising bluff body effects and improving accuracy. Designed for use with 8" to 52" pipelines, it is robust enough to be inserted into the central area of the pipeline.

The 210EH Probe is installed through an isolation valve and can be inserted and withdrawn under process conditions by a Jiskoot Hydraulic Extractor (see hydraulic extractor datasheet).

Established as one of the key instruments in the sampling process for fiscal transfer and quality assessment, the 210EH Probe has a vast worldwide installed base and is seen as one of the most reliable platforms on which to build a sampling system.

### Three stage positive displacement action

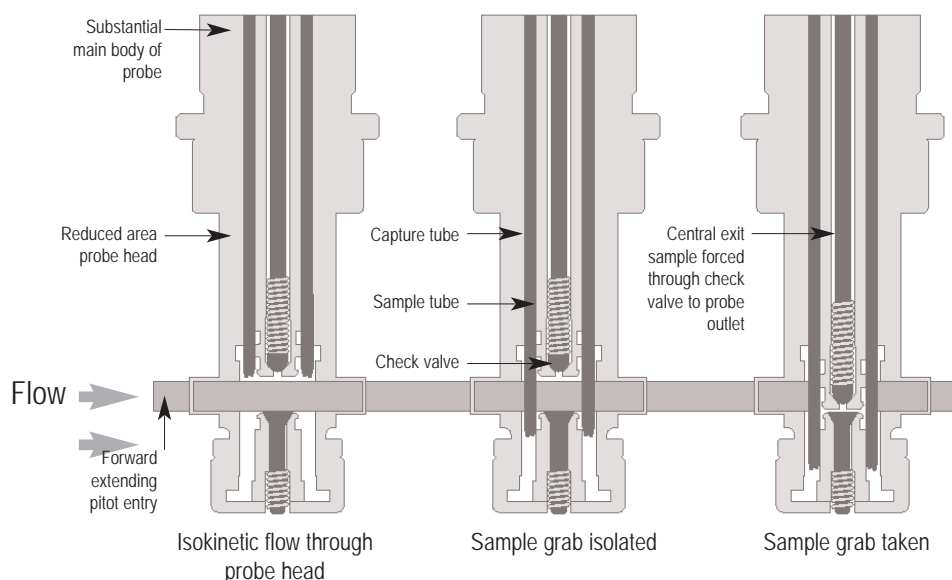

Data Sheet S101-0707-5 • 210EH Probe & 210EH-HP Probe



## Specification

<b>Fluids sampled</b>	Crude oil, refined hydrocarbons (including non-lubricating products) & non-corrosive chemicals					
<b>Viscosity range</b>	0.5 to 8000 cSt.					
<b>Process temperature range</b>	Flange dependant					
<b>Ambient temperature range</b>	-20°C to +65°C (-4°F to +149°F)					
<b>Max. operating pressure</b> (standard materials of construction)	Class	38°C	50°C	100°C	150°C	200°C
	150#	19.6	19.2	17.7	15.8	13.8
	600#	102	100	93	90	87.6
	900#	153	150	139	135	131
	1500#	255	250	233	225	219
<b>Seal Temperature</b>	Standard: -20°C to +90°C (-4°F to +194°F)					
<b>Configuration</b>	In-line withdrawable (Standard extractor required)					
<b>Pipeline size range</b>	Sizes A, B & C - see diagram for suitability					
<b>Mounting arrangements</b>	3" nominal bore - flanged - ANSI class 150, 300 or 600 - RF or RTJ (other standard flanges available on request)(56mm minimum diameter)					
<b>Max. pipeline velocity</b>	Size A: 9.4 m/s, Size B: 6.9 m/s, Size C: 4.8 m/s (Dependent on viscosity)					
<b>Sample grab size (nominal)</b>	1.04cc or 2.04cc (conversion kits available)					
<b>Grab size repeatability</b>	Better than ±2%					
<b>Grab size adjustment</b>	1 cc version ±20% - 2cc version +0 / -10%					
<b>Max. grab rate**</b>	<b>210EH:</b> 30 grabs per min			<b>210EH-HP:</b> 15 grabs per min		
<b>Sample outlet connection</b>	1/8" NPT female					
<b>Standard materials</b>	Seal housing: ASTM A350 LF2 Carbon steel (316 available) as class construction above Wetted parts: 316/304 Stainless steel, (NACE certification available) Standard seals: Graphite filled P.T.F.E., Standard O' rings: Viton (Kalrez available*)					
<b>Operating standards and CE compliance</b>	ISO 3171, API 8.2, IP 6.2, PED - 97/23/EC, Machinery directive - 98/37/EC					
<b>Approximate weight</b>	<b>210EH:</b> 38kg (84lb)			<b>210EH-HP:</b> 39kg (86lb)		

## Actuation data

<b>Actuation method</b>	Hydraulic	
<b>Hydraulic supply**</b>	20 l/min @ 7 bar	
<b>Consumption**</b>	<b>210EH:</b> 7.62 l/min @ 30 grabs/min	<b>210EH-HP:</b> 2.4 l/min @ 15 grabs/min
<b>Actuator connections</b>	2 x 1/4"NPT female	

\*Charges made for these items, \*\*ACFM reflects the actual swept vol--lume for 30 sample cycles without allowance for interconnection piping, rate, consumption, seal life and supply requirements are dependant on process conditions, i.e. line pressure and fluid viscosity.

\*\*Maximum grab

Fitted to valve

### 210 Probe suitability for line sizes

	8"	10"	12"	14"	16"	18"	20"	22"	24"	26"	28"	30"	32"	34"	36"	38"	40"	42"	44"	46"	48"	50"	52"			
2" 150#	A	14 TO 36											36 TO 52													
	B	14 TO 36											36 TO 52													
	C	NOT AVAILABLE																								
2" 300#	A	12 TO 30											30 TO 52													
	B	12 TO 30											30 TO 52													
	C	NOT AVAILABLE																								
3" 150#	A	12 TO 32											14 TO 36													
	B	12 TO 32											14 TO 36													
	C	NOT AVAILABLE																								
3" 300#	A	8 TO 18			18 TO 38											38 TO 52										
	B	8 TO 18			18 TO 38											38 TO 52										
	C	8 TO 18			18 TO 38											38 TO 52										
3" 600#	A	NOT AVAILABLE																								
	B	10 TO 26											26 TO 52													
	C	10 TO 26											26 TO 52													
3" 900#	A	NOT AVAILABLE																								
	B	8 TO 18			18 TO 46																					
	C	8 TO 18			18 TO 46																					

Dim 'A' - Distance from top of pipeline to mounting flange.(incorporating pipe stub and standard length ball valve)

2" - Versions are special order only, 2" - Full-bore ball valve must be used  
300# interchangeable with 600#, 600# supplied as standard

### Material de-rating (ASTM A350 LF2)

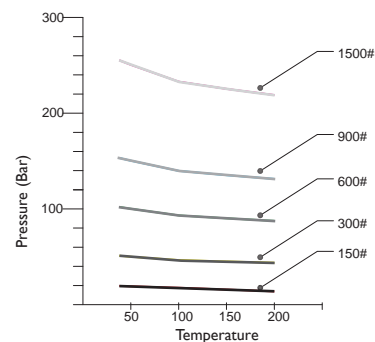

**UK**  
Jiskoot Quality Systems

Tel: +44 (0)1892 518000  
Fax: +44 (0)1892 518100

Email: ms-jiskootuksales@c-a-m.com

**USA**  
Jiskoot Quality Systems

Tel: +1 281 583 0583  
Fax: +1 281 583 0587

Email: ms-jiskootusales@c-a-m.com

**Cameron**  
Measurement Systems

Tel: +1 281 582 9500  
Fax: +1 281 582 9599

Email: ms-marketing@c-a-m.com

Jiskoot Quality Systems  
A Cameron Company  
[www.jiskoot.com](http://www.jiskoot.com)

