



High Temperature Probes

210P, 210P-HP & 210EH, 210EH-HP



The high temperature 210 Probe is a reliable and accurate sample extraction device, suitable for use as part of an in-line sampling system. Available in standard and high pressure versions, it is the ideal solution for a wide range of liquid sampling applications.

The high temperature 210 Probe has a unique three-stage positive displacement action giving accurate sampling irrespective of variations in process pressure or fluid viscosity. The mechanism that traps the sample is at the end

of the insertion device and has a large, pitot style, flow entry, minimising bluff body effects and improving accuracy. Designed for use with 8" to 52" pipelines, it is robust enough to be inserted into the central area of the pipeline.

By installing the 210 Probe through an isolation valve, it can be inserted and withdrawn under process conditions by means of a Jiskoot Hydraulic Extractor (see hydraulic extractor datasheet).

Established as one of the key instruments in the sampling process for fiscal transfer and quality assessment, the 210 Probe has a vast world-wide installed base and is seen as one of the most reliable platforms on which to build a sampling system

Data Sheet SI29-0709-1 • High Temperature Probes

Three stage positive displacement action

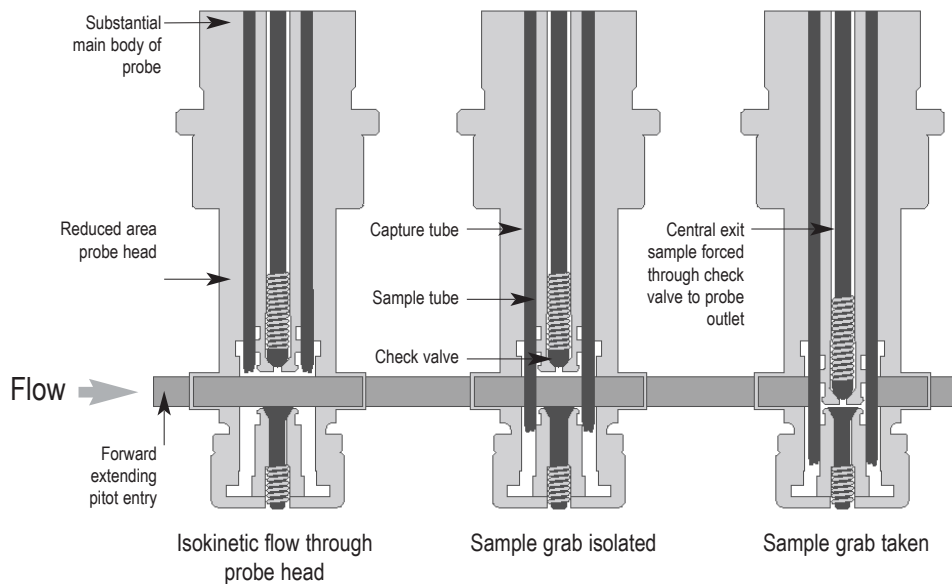



Specification

| | | | | | | |
|--|---|-----------------------------|------------------|---------------------|-------|-------|
| Fluids sampled | Crude oil, refined hydrocarbons (including non-lubricating products) & non corrosive chemicals | | | | | |
| Viscosity range | 0.5 to 8000 cSt. | | | | | |
| Process temperature range | Flange dependant | | | | | |
| Ambient temperature range | -20 to +65°C (-4 to +149°F) | | | | | |
| Max. operating pressure (standard materials of construction) | Class | 38°C | 50°C | 100°C | 150°C | 200°C |
| | 150# | 19.6 | 19.2 | 17.7 | 15.8 | 13.8 |
| | 600# | 102 | 100 | 93 | 90 | 87.6 |
| | 900# | 153 | 150 | 139 | 135 | 131 |
| | 1500# | 255 | 250 | 233 | 225 | 219 |
| Seal Temperature | -23°C to +200°C (-9°F to +392°F) | | | | | |
| Configuration | In-line withdrawable (non-standard flanges available on request) | | | | | |
| Pipeline size range | Sizes A, B & C - see diagram for suitability | | | | | |
| Mounting arrangements (request) | 3" nominal bore - flanged -ANSI class 150, 300 or 600 - RF or RTJ (other standard flanges available on request) | | | | | |
| Max. pipeline velocity | Size A: 9.4 m/s, Size B: 6.9 m/s, Size C: 4.8 m/s (dependent on viscosity) | | | | | |
| Sample grab size (nominal) | 1.04cc or 2.04cc (conversion kits available) | | | | | |
| Grab size repeatability | Better than ±2% | | | | | |
| Grab size adjustment | 1cc version ±20% - 2cc version +0 / -10% | | | | | |
| Max. grab rate** (per min) | 210P: 120, | 210P-HP: 60 | 210EH: 30 | 210EH-HP: 15 | | |
| Sample outlet connection | 1/8" NPT female | | | | | |
| Standard materials | Seal housing: ASTM A350 LF2 Carbon steel (316 available) as class construction above, Wetted parts: 316/304 Stainless steel, (NACE certification available) Standard seals: Graphite filled P.T.F.E., Standard O' rings: Viton (Kalrez available*) | | | | | |
| Operating standards and CE compliance | ISO 3171, API 8.2, IP 6.2, PED - 97/23/EC, Machinery directive - 98/37/EC | | | | | |
| Approximate weight | 210P: 38kg (84lb), | 210P-HP: 39kg (86lb) | 210EH: 38 | 210EH-HP: 39 | | |

Actuation data

| | |
|--|---|
| Actuation method | 210P & 210P-HP: Pneumatic 210EH & 210EH-HP: Hydraulic |
| Air supply range** | 210P & 210P-HP 4-10 bar / 60-145 psi (lubricated) 210EH & 210EH-HP: N/A |
| Air consumption** (30 grabs/min) | 210P: 0.47 ft ³ /min [ACFM] - (0.8m ³ /hr) 210P-HP: 1ft ³ /min [ACFM] - (1.9m ³ /hr) 210EH: N/A 210EH-HP: N/A |
| Actuator connections | 2 x 1/4" NPT female |

*Charges made for these items, **ACFM reflects the actual swept volume for 30 sample cycles without allowance for interconnection piping.

**Maximum grab rate, consumption, seal life and supply requirements are dependant on process conditions, i.e. line pressure and fluid viscosity.

Fitted to valve

210 Probe suitability for line sizes

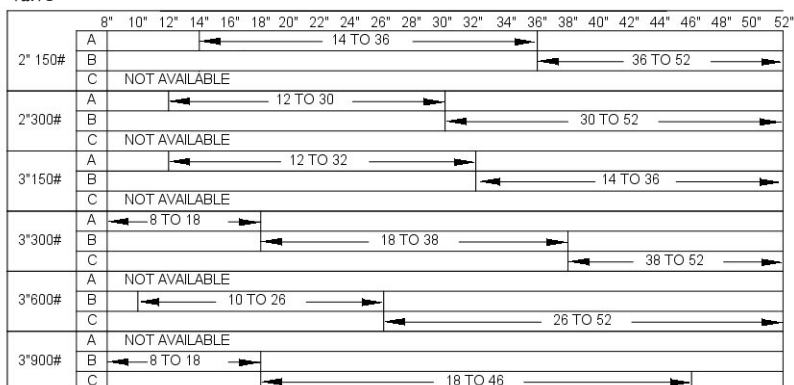

Dim 'A' - Distance from top of pipeline to mounting flange. (incorporating pipe stub and standard length ball valve)

2" - Versions are special order only, 2" - Full-bore ball valve must be used, 300# interchangeable with 600#, 600# supplied as standard

Material de-rating (ASTM A350 LF2)

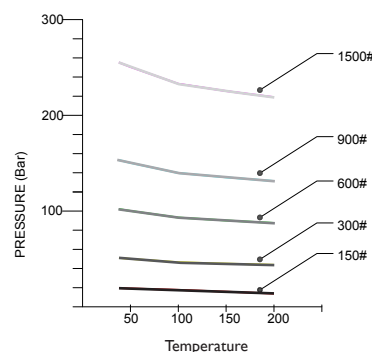

UK
Jiskoot Quality Systems

Tel: +44 (0)1892 518000
Fax: +44 (0)1892 518100

Email: ms-jiskootuksales@c-a-m.com

USA
Jiskoot Quality Systems

Tel: +1 281 583 0583
Fax: +1 281 583 0587

Email: ms-jiskootusasales@c-a-m.com

Cameron
Measurement Systems

Tel: +1 281 582 9500
Fax: +1 281 582 9599

Email: ms-marketing@c-a-m.com

Jiskoot Quality Systems
A Cameron Company
www.jiskoot.com



www.c-a-m.com/flo